

E-Plex 2000 Series

PowerPlex 2000 Series

Installation Instructions

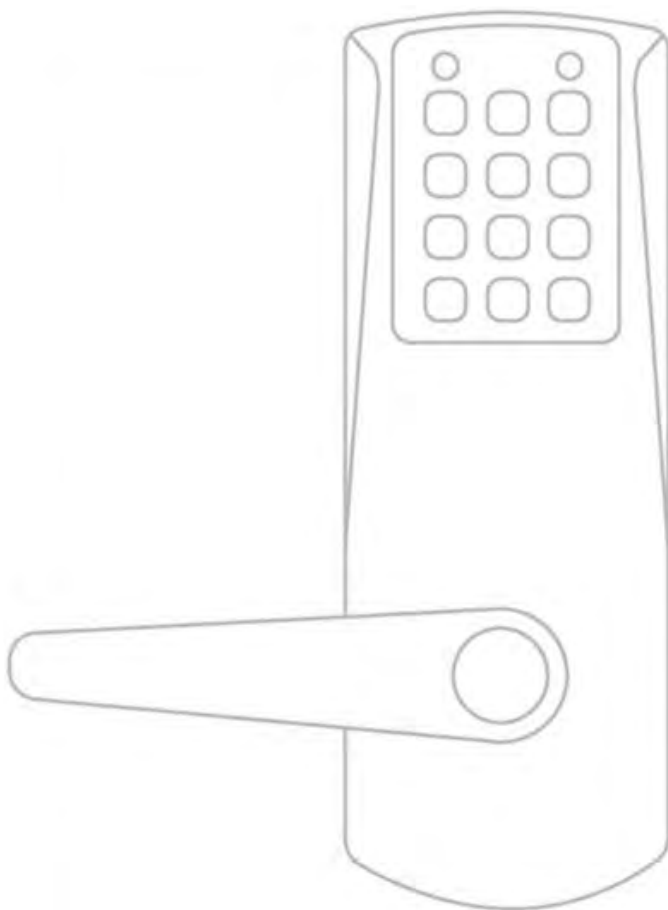

APPLICABLE FOR UNITED KINGDOM INSTALLATIONS ONLY

It is the responsibility of the installer to ensure that the installation of this product complies with the relevant regulations applicable to the territory / country (UK only).

- This lock was included in a successful fire test (EN 1634-1) on a timber door, which relied on the use of intumescent protection as detailed below.
- This protection must be replicated exactly, to ensure that the performance of a similar fire door is not compromised.

Intumescent gasket requirements for fire doors

Product	Fire Door type - timber or mineral composite (to BS EN 1634-1)	Around tubular latch or lockcase	Behind forend	Behind strike plate (and any back box)	Kaba Pack
E-plex 5000 E-plex 5200 E-plex 5600 E-plex 5700	1 hr - 53 mm thick or ½hr - 44 mm thick	Interdens sheet x 1 mm thick	Interdens sheet x 2 mm thick	Interdens sheet x 2 mm thick	Pack 1 KABA-CYLINDER-PACK-1
E-plex 2000 PowerPlex 2000	1 hr - 53 mm thick or ½hr - 44 mm thick	Interdens sheet x 1 mm thick	Interdens sheet x 2 mm thick	Interdens sheet x 1 mm thick	Pack 1 KABA-CYLINDER-PACK-1
Simplex 1000 Simplex L1000 Simplex 5000 Simplex 6200 Simplex 8100	1 hr - 53 mm thick or ½hr - 44 mm thick	Interdens sheet x 1 mm thick	Interdens sheet x 2 mm thick	Interdens sheet x 2 mm thick	Pack 1 KABA-CYLINDER-PACK-1
Simplex 7100 with tubular latch or tubular bolt	½hr - 44 mm thick	Interdens sheet x 1 mm thick	Interdens sheet x 2 mm thick	Interdens sheet x 1 mm thick	Pack 2 ITL-KABA-7000-1

Door types covered by the test evidence

- Single leaf or double leaf, single action timber or mineral composite doorset tested to EN 1634-1
- Minimum leaf thickness
 - 60 minutes - 53 mm
 - 30 minutes - 44 mm
- The leaves should have hardwood lippings of minimum 6 mm thickness and a minimum density of 630 kg/m³
- The door frame of 30 minute doorsets shall be of softwood or hardwood with a minimum density of 450 kg/m³
- The door frame of 60 minute doorsets shall be of softwood or hardwood with a minimum density of 630 kg/m³
- For all 60 minute applications, the door leaf shall include non-combustible sub-facings

TABLE OF CONTENTS

A. Cylindrical Installation	4
B. Mortise Installation	11
C. Exit Trim Installation.....	29
D. Installing Outside Lever on Non-Mechanical Override	33
E. Reversing the Outside Lever for Series Without Mechanical Override..	33
F. K-I-L Cylinder Adaptor Assembly Instructions.....	34
G. Installing Optional K-I-L Key or Best Removable Core	35
Override and Outside Lever	
H. Testing the Operations of the Outside Lever.....	37
I. Testing the Mechanical Key Override with Change Key	38
J. Changing Lock Cylinders	39
K. Changing Best-Type Core.....	40
L. Removing and Reassembling the Outside Lever.....	40
M. Installing Rubber Bumpers.....	41
N. Installing Battery Pack	41
O. Testing the Operation of the Lock.....	42

Product Warranty and Registration:

For Product Warranty, Terms and Conditions, please visit:
www.dormakaba.com/us-en/support/product-warranty--terms---conditions

To register your product, please visit:
www.dormakaba.com/us-en/support/simplex-eplex-lock-registration

For technical assistance, call 1-800-849-8324

Please read and follow all directions carefully.

These instructions are designed for use by maintenance professionals or lock installers who are familiar with common safety practices and competent to perform the steps described. dormakaba is not responsible for damage or malfunction due to incorrect installation.

Important: Carefully inspect windows, doorframe, door, etc. to ensure that the recommended procedures will not cause damage. dormakaba standard warranty does not cover damages caused by installation.

A. CYLINDRICAL

CHECKLIST

Parts and Tools List

Each E-Plex/PowerPlex 2000 lockset includes:

- Outside lock housing
- Inside lock assembly
- Outside lever
- Gasket for outside lock housing (not for PowerPlex 2000 versions)
- Cylindrical latch
- Cylinder drive unit
- Battery holder with 3 AA batteries (not included in PowerPlex 2000 versions)
- Drilling templates
- Hardware bag, includes:
 - Square spindle
 - Phillips screw (6-32 x $\frac{5}{16}$ ") (not for PowerPlex 2000 versions)
 - Strike kit
 - (3) mounting screws (12-24, $\frac{1}{8}$ " hex head)
 - Allen Key $\frac{1}{8}$ " – Allen Key $\frac{5}{64}$ "
 - (2) 1" (25 mm) Phillips mounting screws
 - (1) extension spring
 - (4) pairs of Flat Head screws 10-24
 - (3) spacers
- Key Override (Optional)
 - (1) cylinder with 2 keys for override (if equipped)
 - (1) cylinder plug (if equipped)
 - (1) cylinder cap (if equipped)
 - (2) adaptors for best-type cylinders (if equipped)
 - (1) override shaft tool (if equipped)

Warning: For E-Plex/PowerPlex 2000 locks, the Master Code of this lock has been factory preset: 1,2,3,4,5,6,7,8. To activate lock functions, the master combination must be changed at the time of installation.

TOOLS REQUIRED:

- Safety glasses
- 1/2" (13 mm) chisel
- 1/8" (3 mm) drill bit
- 1/2" (13 mm) drill bit
- 7/8" (22 mm) drill bit or hole saw
- 1" (25 mm) drill bit or hole saw
- 2 1/8" (54 mm) hole saw
- Drill
- Awl or center punch
- Rubber mallet
- Small flat screwdriver (less than 1/8")
- Phillips screwdriver (#2)
- Fine steel file
- Router
- Adjustable square
- Tape measure
- Pencil
- Tape
- Cleaning supplies (drop cloth, vacuum)
- Spanner screwdriver #6

DIAGRAM OF LOCK:

- | | | |
|----------------------|-----------------------|---------------------------------|
| (A) Lock housing | (E) Lever catch | (I) Cylinder (if equipped) |
| (B) Inside drive hub | (F) Countersink | (J) Cylinder plug (if equipped) |
| (C) Nylon washer | (G) Outside Lever | |
| (D) Drive tube | (H) Cap (if equipped) | |

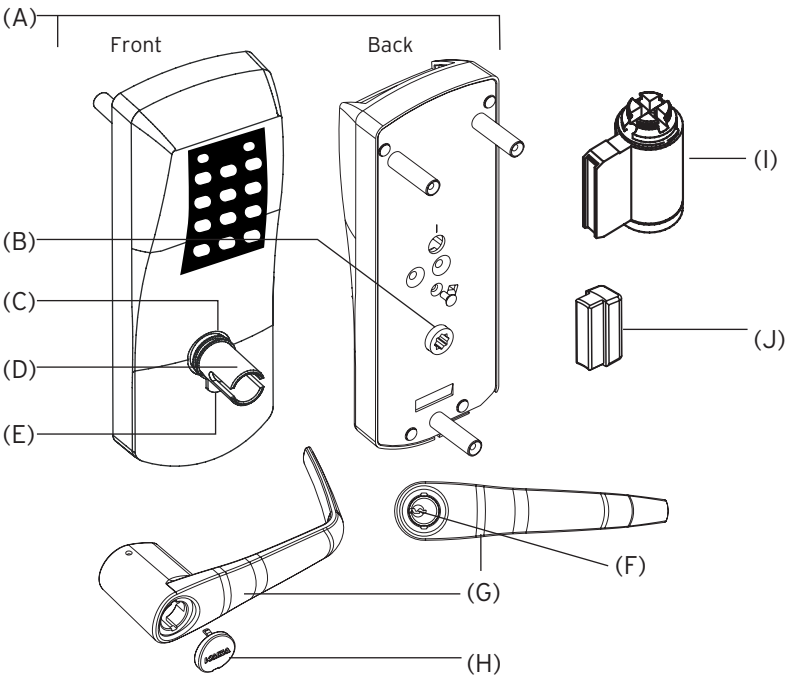

A-1. Door Preparation

Note: Drill from both sides of the door to prevent unsightly damage.

1. Determine which template fits your E-Plex 2000 installation (either the 2 3/8" [60 mm] Backset or the 2 3/4" [70 mm] Backset).
2. Place appropriate paper template (supplied) onto door and mark for holes. Drill the three 1/2" (13 mm) holes first. Next drill the 2 1/8" (54 mm) cross bore hole. Drill the 1" (25 mm) hole last.
3. Mortise door edge for latch unit faceplate 3/16" (5 mm) deep to dimensions shown. Insert latch unit into the 1" (25 mm) hole, making certain that the latch bolt bevel faces direction of closing door.
4. Secure the latch to the door using two 1" (25 mm) Phillips Mounting screws supplied. Latch unit faceplate must be flush with door (for doors with 1" diameter hole, use sleeve on latch).

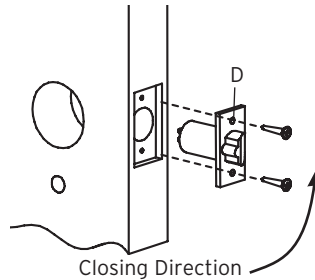
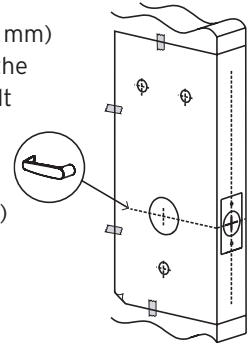

A-2. LOCK HANDING

The E-Plex 2000 is a non-handed lock that is preassembled for left-hand door installations.

1. Determine the hand of your door. For Left Hand doors, proceed to section C. For Right Hand doors, follow steps below.

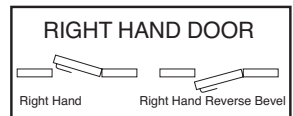
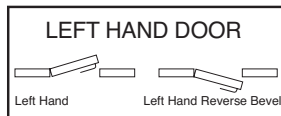

2. Remove the two connecting screws from the cylindrical drive unit. Rotate cylindrical drive unit 180°. Reposition spacer(s) as found before disassembly. Remount drive unit with the two connecting screws.

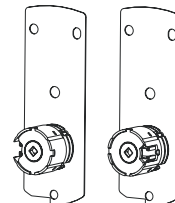

LH Assembly RH Assembly
Cylindrical Drive Unit Position

A-3. DOOR THICKNESS

Depending on the kind of spacers shipped with the lock, choose Table 1 or Table 2 to prepare the attachment plate and cylindrical drive unit for door thickness different than 1 3/4" assembled in the factory.

Note: It is very important to assemble the spacers in the position shown.

1. LOCK WITH 3 DIFFERENT SPACERS

The cylindrical unit and plate assembly is shipped assembled in factory for 1 3/4" (44 mm) door thickness (1 11/16" [43 mm] to less than 1 7/8" [48 mm]) with 2 spacers "04"; 1 spacer "02" and 2 flat head screws 5/8" LG. For other door thicknesses, use Door Thickness Table 1 for appropriate spacers and screws included in the hardware bag.

Prepare attachment plate and cylindrical drive unit for door thicknesses less than 1 11/16" (43 mm) or 1 7/8" (48 mm) and above according to the [Door Thickness Table 1](#).

Correct Position of Spacers

See Table 1

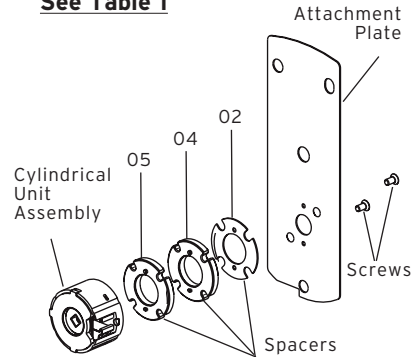

Door Thickness Table 1

Door Thickness	Spacer 02	Spacer 03	Spacer 04	Screw Length
1 3/8" (35 mm) to 1 9/16" (40 mm)	-	1	-	3/8" (10 mm)
Over 1 9/16" (40 mm) to less than 1 11/16" (43 mm)	-	2	-	1/2" (13 mm)
1 3/4" (44 mm) DOOR 1 11/16" (43 mm) to less than 1 7/8"	1	2	-	5/8" (16 mm)
1 7/8" (48 mm) to 1 15/16" (49 mm)	1	-	1	5/8" (16 mm)
Over 1 15/16" (49 mm) to less than 2 1/8" (54 mm)	2	-	1	3/4" (19 mm)
2 1/8" (54 mm) to 2 3/16" (56 mm)	-	1	1	3/4" (19 mm)
Over 2 3/16" (56 mm) to 2 3/8" (60 mm)	2	1	1	7/8" (22 mm)
Over 2 3/8" (60 mm) to 2 1/2" (64 mm)	-	-	2	7/8" (22 mm)

2. LOCK WITH 2 DIFFERENT SPACERS

The cylindrical unit and plate assembly is shipped assembled in factory for 1 3/4" (44 mm) door thickness up to 1 13/16" [46 mm] with 2 spacers "07"; 1 spacer "08" and 2 flat head screws 5/8" (16 mm) long. For other door thicknesses, use Door Thickness Table 2 for appropriate spacers and screws included in the hardware bag.

Correct Position of Spacers See Table 2

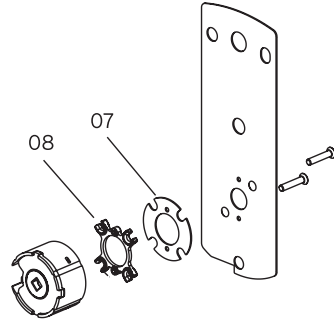

Door Thickness Table 2

Door Thickness	Spacer 07	Spacer 08	Screw Length
1 3/8" (35 mm) to 1 9/16" (40 mm)	2	-	3/8" (10 mm)
1 5/8" (41 mm) to 1 11/16" (43 mm)	1	1	1/2" (13 mm)
1 3/4" (44 mm) to 1 13/16" (46 mm)	2	1	5/8" (16 mm)
1 7/8" (48 mm) to 1 15/16" (49 mm)	-	2	5/8" (16 mm)
2" (51 mm) to 2 1/16" (52.5 mm)	1	2	3/4" (19 mm)
2 1/8" (54 mm) to 2 3/16" (56 mm)	2	2	3/4" (19 mm)
2 1/4" (57 mm) to 2 5/16" (59 mm)	-	3	7/8" (22 mm)
2 3/8" (60 mm) to 2 1/2" (64 mm)	1	3	7/8" (22 mm)

Screw Length	Full Scale
Length 3/8" (10 mm)	
Length 1/2" (13 mm)	
Length 5/8" (16 mm)	
Length 3/4" (19 mm)	
Length 7/8" (22 mm)	

A-4. INSTALLING LOCK HOUSINGS

1. Remove the cylindrical plate assembly from the outside housing (a). Insert the slotted end of the square spindle into the outside housing lever hub until it locks, at an angle of 45°. (The spindle can be removed by pulling on it, if oriented incorrectly.)

Square Spindle Position

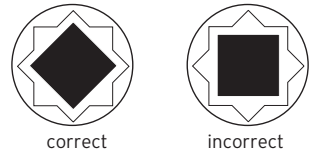

2. Assemble gasket onto the outside housing (a). Assemble cylindrical plate assembly onto the outside lock housing. (Not required for PowerPlex 2000 versions)

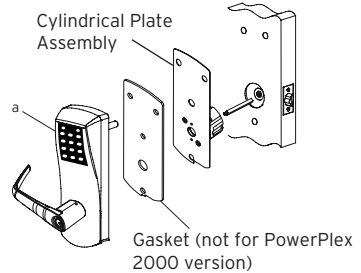

3. Place the outside housing (a) and cylindrical plate assembly on the door so that it engages the latch as shown.

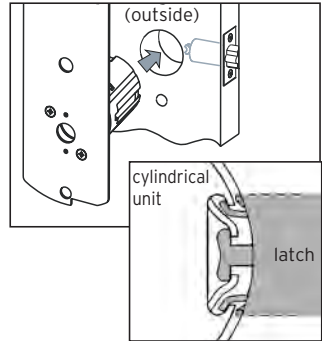

4. On the inside trim assembly, turn the lever to the correct horizontal rest position for the handing of the door. Install the tension spring (l) between the stop plate (h) and the post (p).

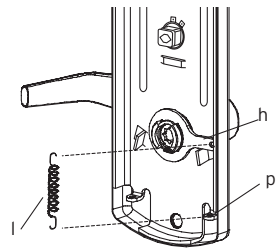

5. The inside trim assembly for cylindrical with privacy models includes parts assembled at the factory to control the motion of the thumbturn, and an additional spring. (continued on next page)

5. (continued from previous page)

Do the following before placing the inside trim assembly on the door:

Install the additional tension spring (i) between the plate (j) and the post (p), on the side opposite the lever handle spring installed in the last step.

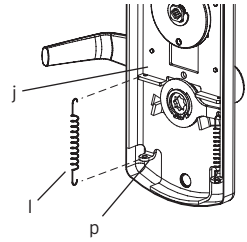

6. Put the thumbturn (T) in a vertical position. Assemble 3 spacers (S) on the door (for recent models only). Place the inside trim assembly on the door so that the upper and lower spindles (F) and (G) engage the thumbturn and the inside lever. Fasten to the outside housing using the three 1/8" hex drive mounting screws (I). Install the screws without tightening. Verify the inside lever and thumbturn operates smoothly. If not move the inside and outside housings slightly. Then tighten the screws.

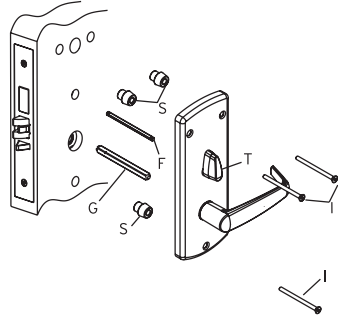

A-5. INSTALLING THE STRIKE

Note: Use only the strike and strike box supplied. The use of non-approved parts will result in a functionality problem and may void the warranty.

1. Mark location of strike on the door frame, making certain that the strike opening is aligned with latch bolt.
2. Mortise doorframe for strike $3\frac{3}{32}$ " (3 mm) deep minimum to dimensions shown. Make cut out for dust box. Secure strike to the door frame using two 1" (25 mm) combination screws.

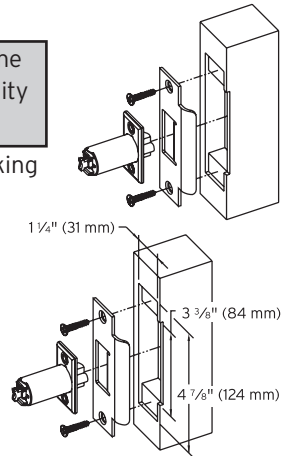

Caution: Check the operation of the latch by making sure that the deadlatch stops against the strike as shown and does not slide into the strike opening when the door is closed. If that situation occurs, then a total lockout may occur. This will void our warranty of the complete lock mechanism. If necessary, correct the door over-travel by using the rubber bumpers as described in Section P (Installing Rubber Bumpers).

B. MORTISE

Checklist and Exploded Views (Mortise Only)

Each E2000 Mortise lockset includes:

(A) Outside lever handle

(or)

Parts for Mechanical override model only:

(A1) Outside lever handle

(B1) Outside housing

(C1) Cylinder plug

(D1) Cylinder (for locks with KIL option)

(E1) Cylinder cap

(E2) Instruction sheet "How to attach lever on lock"

(B) Outside housing

(C) Battery holder with 3 AA batteries (not for PowerPlex 2000 versions)

(D) Mortise (ASM only shipped assembled with faceplate and 2 x 8-32 x 1/4" screws)

(E) Inside trim assembly, details depend on lock model

(E3) Drilling template

(N) Outdoor Gasket (not for PowerPlex 2000 versions)

Parts inside hardware bag:

(F) Thumbturn (hex) spindle

(G) Square spindle

(H) Phillips screw (6-32X 5/16") (not for PowerPlex 2000 versions)

(I) 3 x mounting screws (12-24, 1/8" Hex Head)

(J) 2 Machined screws (12-24X 1/2" Philips) & 2 wood screws (#12 X 1" Philips)

(K) Strike kit (screws, strike and dustbox)

(L) 1 extension spring

(R2) 1 Cylinder with 2 keys for E2000 with override

(S) 3 spacers for recent Models only

(T) Allen Key 1/8"

(U) Allen Key 5/64"

Tools Required:

- Safety Glasses
- 1/2" (13mm) chisel
- 1/8" (3mm) drill bit
- 1/2" (13mm) drill bit
- 1" (25mm) drill bit or hole saw
- Drill
- Awl or center punch
- Hammer Rubber mallet
- Small flat screwdriver
- Philips screwdriver (#2)
- Fine steel file
- Mortising machine
- Router
- Mortise faceplate router template
- Adjustable square
- Tape measure
- Pencil
- Tape
- Cleaning supplies (drop cloth, vacuum)

American Standard Mortise illustrated

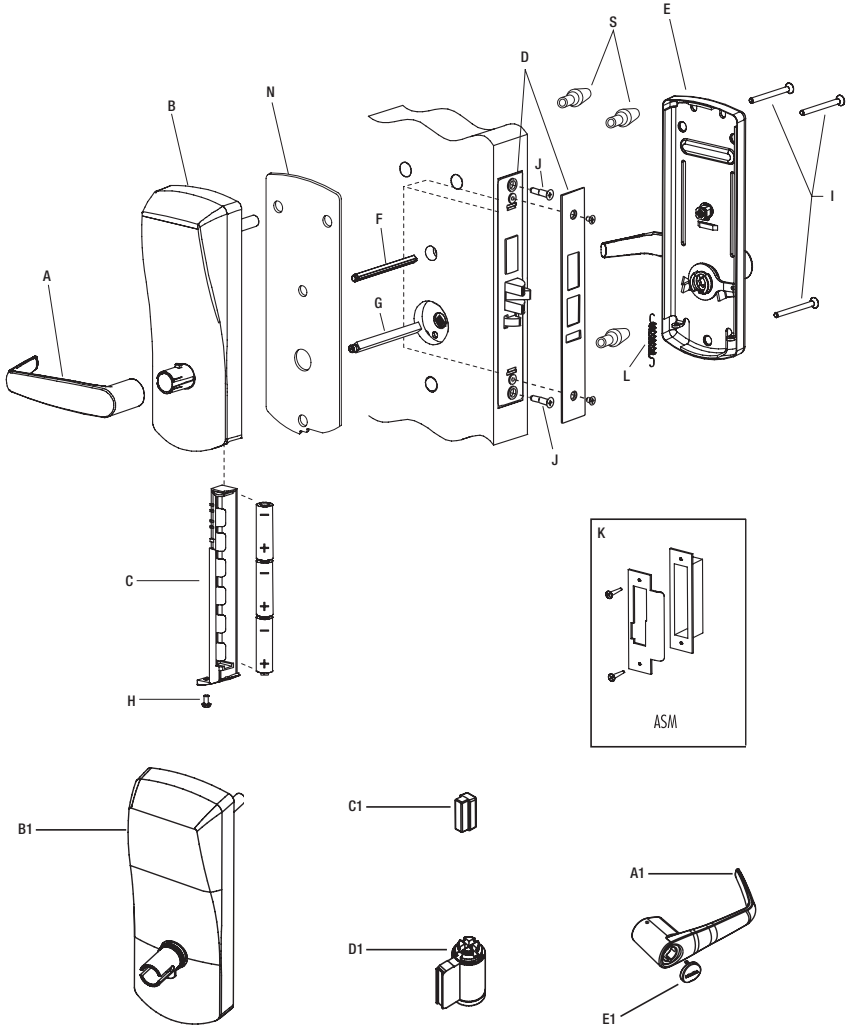

B-1. Installation of Standard ASM Models

1. Check the Mortise Handing

- a. Compare the mortise with the diagram below. If the mortise is the correct handing for the door, continue with step 2.

Note: Refer to B-2 to change the handing of a field-reversible mortise.

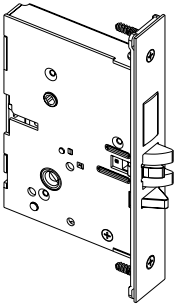

For LH (left hand) and
RHR (right hand reverse)

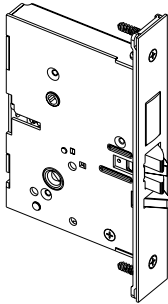

For RH (right hand) and
RHL (left hand reverse)

Door Handing (Top View)

Right Hand (RH)

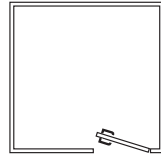

Left Hand (LH)

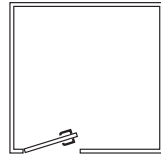

Right Hand Reverse (RHR)

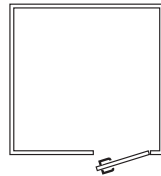

Left Hand Reverse (LH)

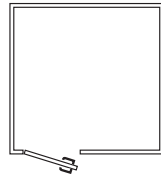

2. Install the Strike

- a. Align the paper template on the door frame at the desired handle height, and along the vertical center line of the mortise (CL), which is also the center line of the door edge, allowing for any bumpers on the door frame.

Note: Respect applicable building codes regarding handle height.

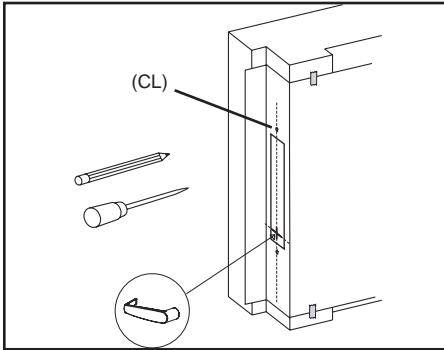

- b. Mark the locations of the dust box cutout and mounting screws for the strike.
- c. Mortise the door frame to receive the dust box, and drill the pilot holes for the mounting screws (dimensions and depths marked on template).

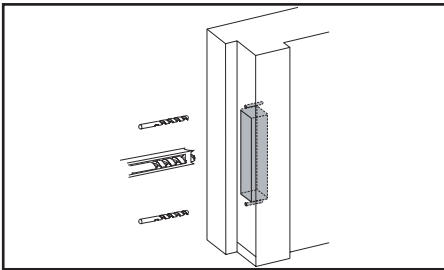

- d. Position the strike against the doorframe and align it with the mounting screw holes. Trace the outline of the strike.

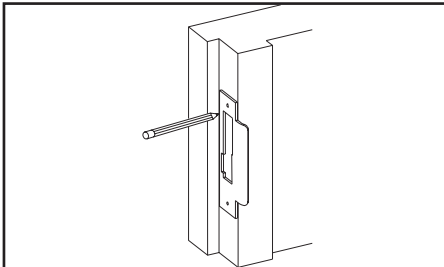

- e. Remove material from within the strike outline so that the strike will be flush with the doorframes.

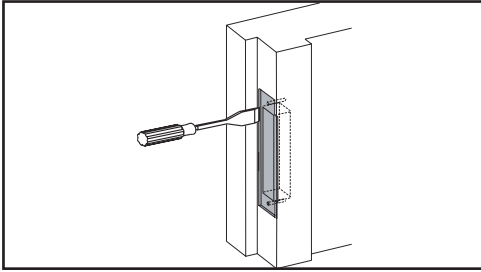

- f. For ASM, install the dust box (optional for wood door frames, required for metal door frames), and check the strike handing on the template. Install the strike using the screws provided. Use wood screws for wood frame and machined screws for steel frames.

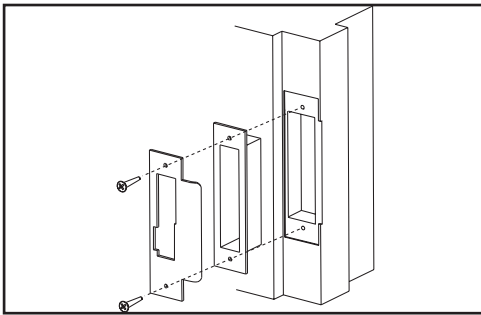

Note: When strike is installed on wood frames under one inch thick, wood screws supplied are not adequate. Use screws of efficient length to engage the structural stud behind the frame. Use only the strike and dust box supplied. Use of non-approved parts may void the warranty.

B-2. Reversing the Mortise Handing

1. Reversible ASM

- a. Remove the mortise faceplate. **Place the mortise on a flat surface for the following steps.**

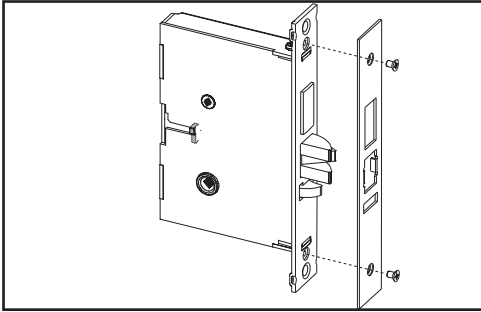

- b. Partially extend the deadbolt:

For normal ASM, rotate hub (H) using a screwdriver, until the deadbolt (D) extends approximately 1/4".

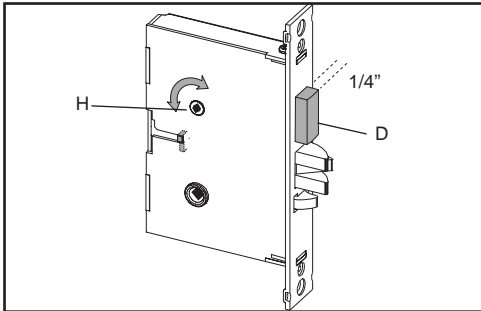

Proceed to step c.

For Autodeadbolt ASM, rotate hub (H) until the deadbolt (D) is fully retracted. The deadbolt will extend approx. 1/16" from the mortise case.

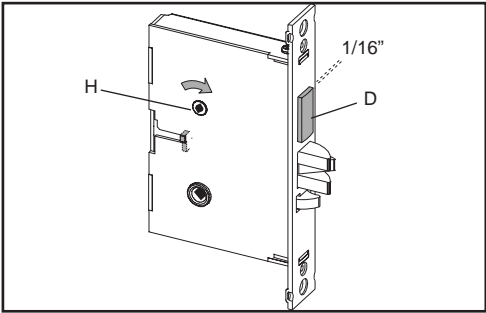

Hold deadbolt (D) gently. Press and release the auxiliary latch (X). You should feel the deadbolt trigger and begin to extend under the force of the spring.

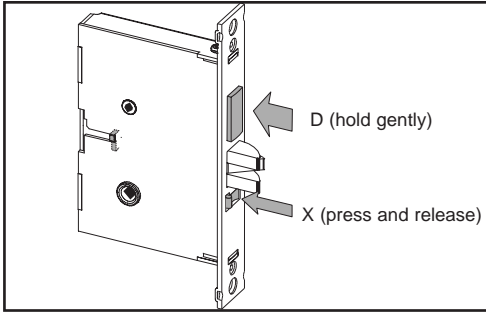

Release the deadbolt (D) gently. It should extend to 5/16" approx. and stop. If the deadbolt extends past this point, gently press it in until it locks at 5/16" throw, or start step b again.

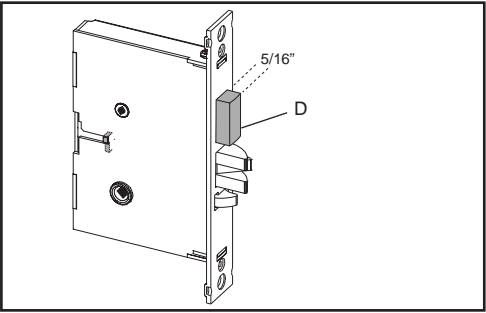

1. Reversible ASM (continued)

- c. Push in the latch bolt (L) to the middle of its stroke, and hold it there.
(Continue Step 1 and 2)

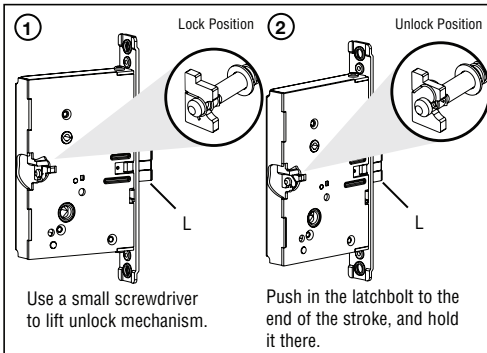

Hold the latch (L) inside the mortise, and insert the tailpiece retaining tool (S, part #027-510382 or #041-513342 available separately) so that the tailpiece (T) will not drop inside the mortise case. Hold the tool and the latch with one hand, and slide up the tailpiece using a small screwdriver.

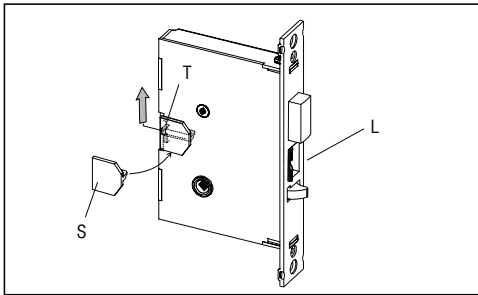

Continue to hold tool (S). Release the latch bolt (L) and keep the anti-friction latch (F) toward the flat side of the latch bolt so that the bolt extends fully.

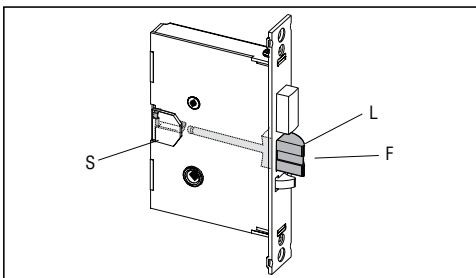

- d. Pull out the latch bolt (L), until it just clears the front plate. (Note: If you remove the bolt completely, you must turn it 90° to re-insert it.)

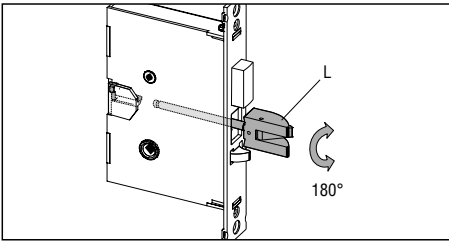

Rotate the latch bolt (L) 180°. Re-insert it to the end of its stroke.

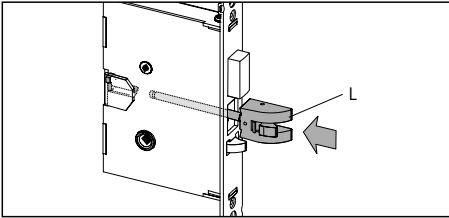

Holding tool (S) in place, re-engage tailpiece (T) with latch bolt (L) (slide tailpiece down). There may be some play required to align the parts. Remove the tool (S).

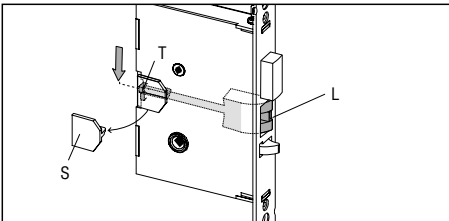

Release the latch to the middle of the stroke and hold it there. Use a small screwdriver to push the lock mechanism back on lock position (see step 1 and 2) .

Note: The lock mechanism has to be horizontal on lock position

- e. Release the latch bolt (L). Position the latch bolt so that the bottom tooth of the anti-friction latch (F) remains inside the mortise case as shown.

Note: If the tooth of (F) is outside the mortise, you will not be able to re-assemble the faceplate on the mortise.

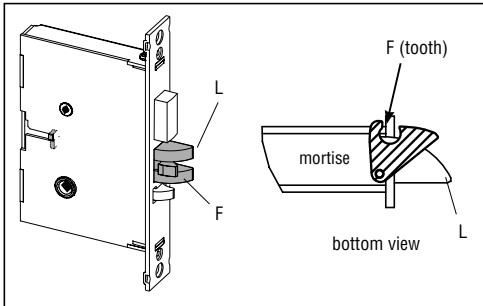

- f. The mortise should look like the diagram below. (Check the orientation of the latch bolt and auxiliary latch.) Check the bevel of the mortise and change it if required as described in section B-4, paragraph 6.

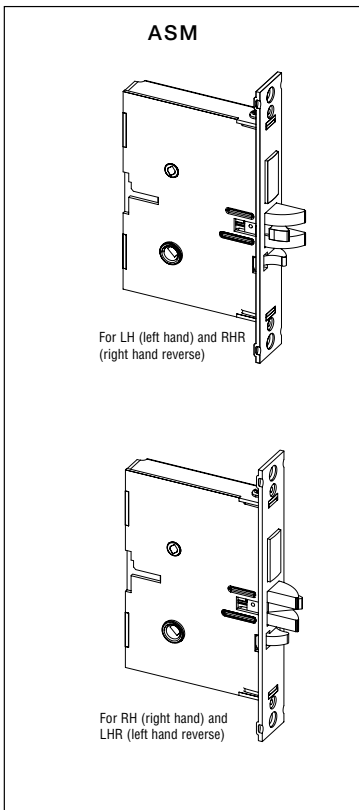

B-3. Additional steps for Autodeadbolt ASM inside trim assembly

If not already installed at the factory, **put the thumbturn in the vertical position and install all four (4) parts (M)** as shown, on the inside trim assembly.

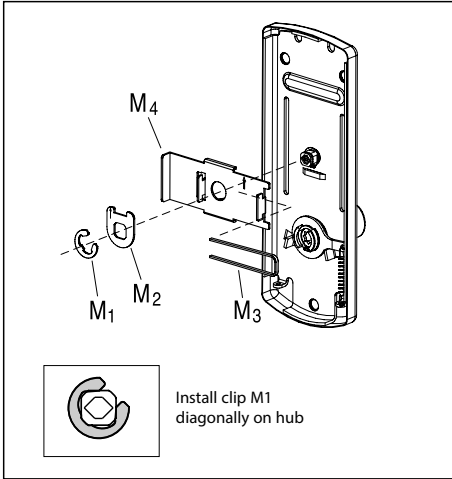

Turn the thumbturn all the way to the right for a RH installation (arrow on M2 points UP), or all the way to the left for a LH installation (arrow on M2 points DOWN). The thumbturn should stop in the vertical position, and the stopper cam (M2) will be in the position illustrated below.

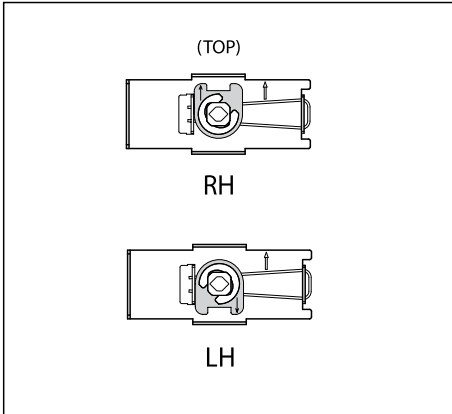

B-4. Install the Mortise

1. Mark the handle height on the edge of the door, as determined directly from the strike.
For ASM, the axis of rotation of the handle is level with the bottom lip of the strike.
2. Align the template along the vertical center line of the mortise (CL) at the desired handle height, and tape it to the door. Mark all holes and cutouts for the mortise in the edge of the door and remove the template.

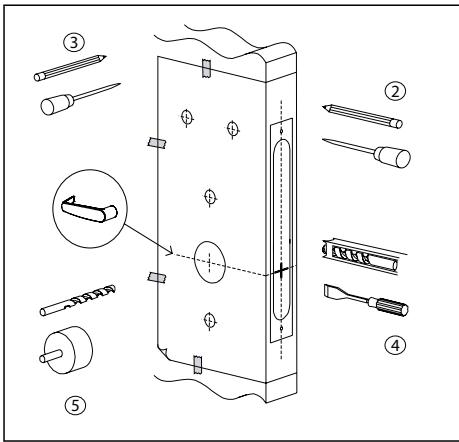
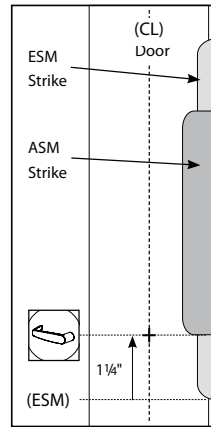

3. Locate the two sets of vertical fold lines on the template allowing you to adjust the positioning of the template depending on the bevel of the door.
If the door has no bevel, fold the template along the solid lines. Align the fold with the edge of the door and mark the holes for the lock. Repeat on the other side of the door.
If the door has a 3° bevel, fold and align the dashed line marked "H" on the template with the higher-beveled edge of the door and mark the lock holes on that side of the door. Repeat on the side with the lower-beveled edge using the dashed line marked "L". Remove the template.

4. Prepare the cut-outs for the mortise in the edge of the door using a mortising machine, router and chisel (for dimensions, refer to template). Ensure clearance is provided for moving latch parts as indicated on the template.

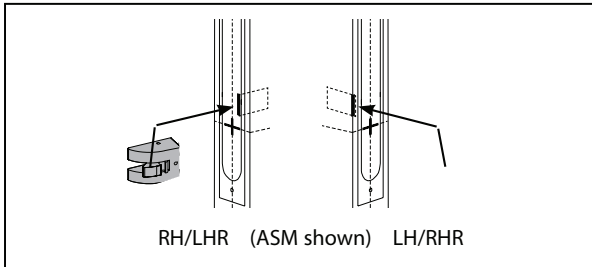

5. Drill the holes in the sides of the door (for dimensions, refer to template).

Note: Drill from both sides of the door to prevent unsightly damage

6. For ASM only, check the bevel of the mortise. If adjustment is required, loosen bevel screws (R) and adjust mortise front plate angle to match the bevel of the door. Re-tighten screws.

Install the mortise with 2 screws (Q). Use wood screws for wood doors and machined screws for steel doors.

Install mortise faceplate (P) with the two 8-32 x 1/4" screws provided.

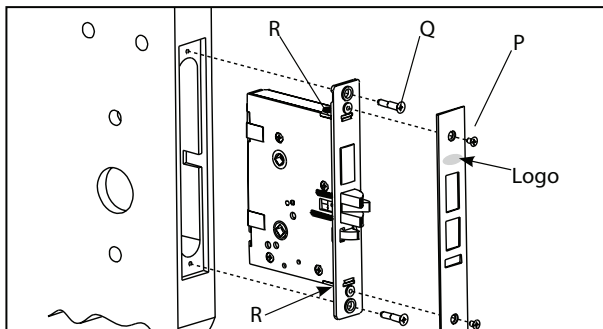

Place 3 spacers (S) on the door (for recent models only). Place the inside trim assembly on the door so that the upper and lower spindles (F) and (G) engage the thumbturn and the inside lever. Fasten to the outside housing using the three 1/8" hex head mounting screws (I).

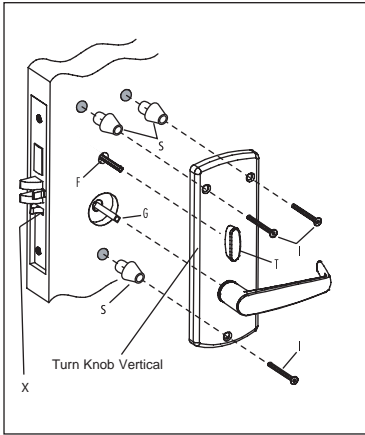

Note: For **Auto Deadbolt** models the gap between the mortise front plate and the strike must not exceed 1/4 "

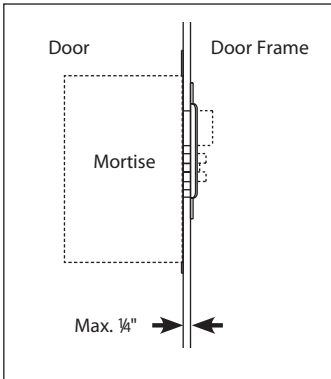

B-5. Install the Outside Housing and Inside Trim Assembly for 2000 Series without Key Override (for E2000 Series Key Override, see Section F)

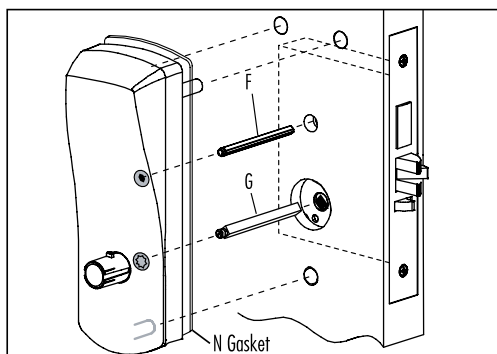

1. Install the gasket (N) (if required) on the outside housing prior to assembly, aligning the notch in the gasket with the battery compartment.

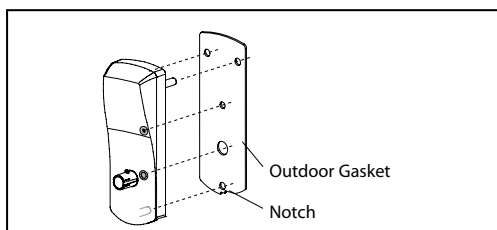

2. Insert the slotted end of the square spindle (G) into the outside lever hub until it locks, at an angle of 45°. (The spindle can be removed by pulling on it, if oriented incorrectly.)

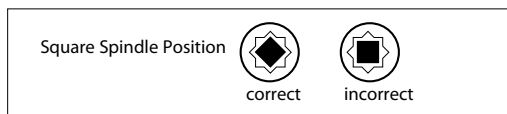

3. Insert the thumbturn spindle (F) in the upper hub of the outside housing. (It will clip in place.)

Note: For doors more than 2 1/2" thick, order the appropriate hardware bag to receive the correct length of spindles and mounting screws.

4. Place the outside housing on the door so that the spindles engage the hubs on the mortise.

5. On the inside trim assembly turn the lever to the correct horizontal rest position for the handing of the door. Install the tension spring (L) between the handle (H) and the post (P).

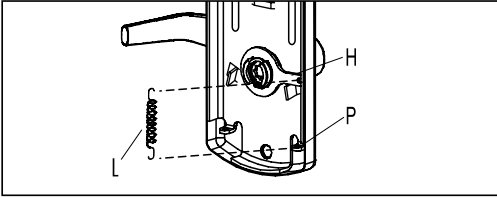

Note: For Autodeadbolt ASM, Office and Storeroom models, refer to section B-3

6. Put the thumbturn (T) in a vertical position. Place 3 spacers (S) on the door (for recent models only) and place the inside trim assembly on the door so that the upper and lower spindles (F) and (G) engage the thumbturn and the inside lever. Fasten to the outside housing using the three 1/8" hex drive mounting screws (I). Install the screws without tightening. Verify the inside lever and thumbturn operates smoothly. If not move the inside and outside housings slightly. Then tighten the screws.

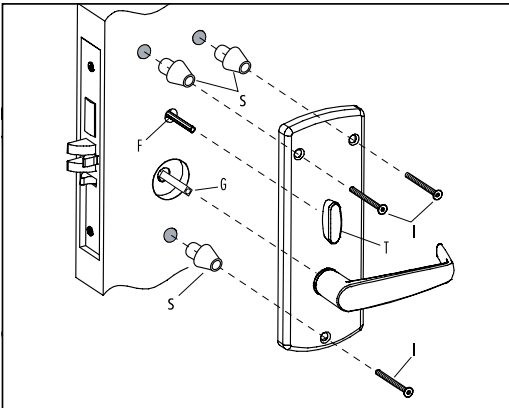

7. Assemble the lever on the outside housing, in the horizontal rest position appropriate to the handing of the door. Simply push the lever onto the tube until it clicks in place. If more force is required, use a rubber mallet. Test the attachment of the handle by pulling smartly on it. (For locks with key override, see p. 31)

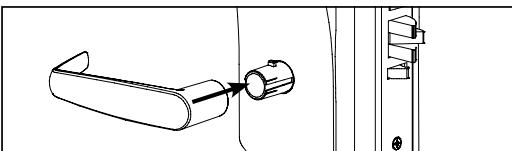

8. Three AA batteries should already be installed in the battery holder (C). Insert the battery holder into the outside housing and secure it using the supplied 6-32 x 5/16" (7.9mm) Phillips screw (H).

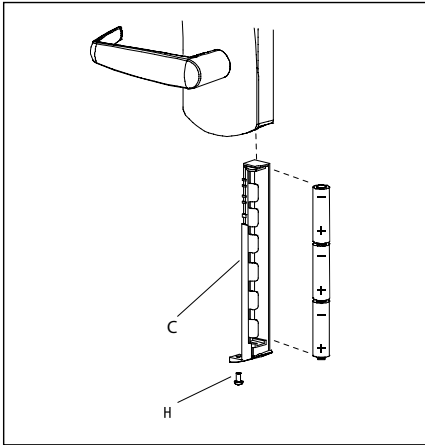

Note: If the lock makes a continuous buzzing noise or the red LED lights continuously, reset the electronics by removing the battery holder for ten seconds then reinsert it.

B-6. Reversing the Outside Lever (for Series without Mechanical Override)

The lever is field reversible. If the handing is incorrect, insert a small pick or flat screwdriver in the hole in the hub as shown. Gently pry back the spring clip inside the hub, and remove the handle.

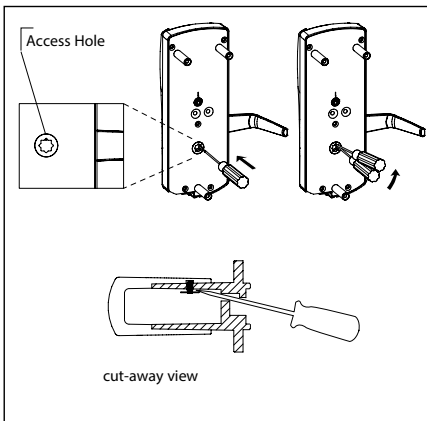

C. EXIT TRIM

C-1. CHECKLIST FOR PRECISION EXIT DEVICES 21/22/ FL21/FL22 VON DUPRIN 98/99EO-F/9827/9927 EO- F/9875/9975/9847/9947

**** DETEX 10/F10/20/F20**

DORMA F9300

YALE 7100/7160/7170

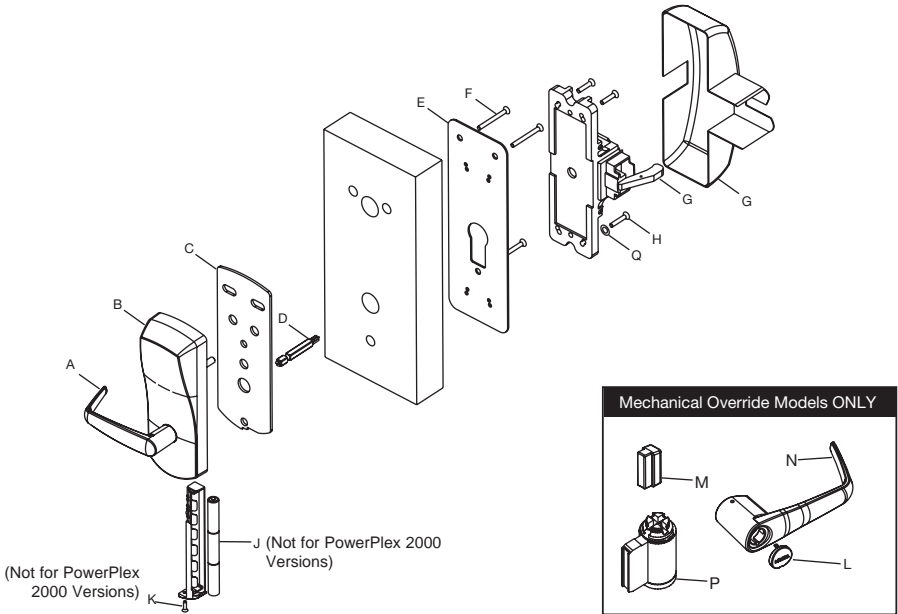

**** Detex 10 & 20 Series are Panic Hardware only. (Not fire rated)
Detex F10 & F20 Series are Fire Exit Hardware (Fire Rated)**

Each ockset includes:

- (A) Outside lever handle
- (B) Outside housing
- (C) Gasket (when required)
- (J) Battery holder with 3 AA batteries

Parts inside hardware bag:

- (D) 1 or more spindles as equipped
- (E) 1 x Inside Adaptor Plate
- (F) 3 x Mounting Screw 12-24 1/8" Hex
- (H) 2 x Pan Head Screws 1/4" 28 X 3/4" for Yale
2 or 4 Pan Head Screws 10-24 X 3/4" for Detex, Dorma,
Von Duprin or 4 Flat Head screw 10-24 X 5/8" for Precision,
Arrow
- (K) 1 x Pan Head Screw
- (Q) 2 or 4 Flat Washer 1/2 OD for Detex Exit Device Only

Mechanical Override Models ONLY:

- (L) Cylinder Cap
- (M) Cylinder Plug
- (N) Outside Lever Handle
- (P) Cylinder (for 630 series lock with cylinders keyed
different ONLY)

Tools Required:

- | | |
|---------------------------------|----------------------------|
| Safety glasses | Spanner screwdriver (No 6) |
| 5/16" (7.9mm) drill bit | 1/8" Allen key |
| 1/2" (13mm) drill bit | Adjustable square |
| 1" (25mm) drill bit or hole saw | Tape measure |
| Drill | Pencil |
| Awl or center punch | Tape |
| Hammer | Cleaning supplies |
| Rubber mallet | (drop cloth, vacuum) |
| Small flat screwdriver | |
| Phillips #2 screwdriver | |

C-2. PREPARE THE DOOR FOR THE APPROPRIATE EXIT DEVICE

1. Choose the drilling template of the lock for the exit device to be assembled on the door.
2. Mark the desired handle height on the edge of the door. (see Fig.1)
3. Mark the backset vertical line on each side of the door. Consult the exit device manufacturer's instructions for the correct backset. The backset shown on the paper template is for reference only. use exit device backset.

Note: Respect all applicable building codes regarding the handle height of the lock and positioning of the bar.

4. Position the drilling template on the inside of the door aligning the door handle height mark and backset vertical line mark with the lines on the template. Mark the door for the holes position.
5. Drill holes to diameters specified on the drilling templates.

Drill the holes in the door required for the exit device according to the manufacturer's instructions.

Note: Drill from both sides of the door to prevent unsightly damage. Refer to template for drill size and depths.

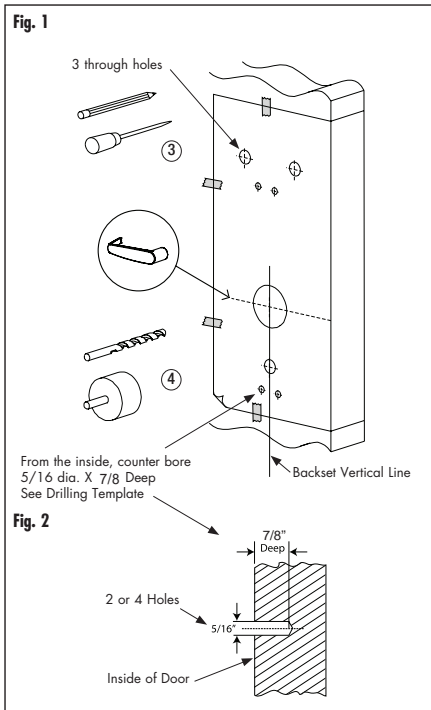

C-3. INSTALL THE LOCK AND EXIT DEVICE

1. Install the Mortise (if applicable)

For mortise exit devices, install the mortise according to the manufacturer's instructions

2. Install the Outside Lever

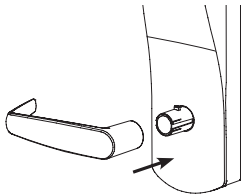

A. Assemble the lever on the outside housing, in the horizontal rest position appropriate to the handing of the door as shown. Simply push the lever onto the tube until it clicks in place. If more force is required to engage the handle, use a rubber mallet. Test the attachment of the handle by pulling smartly on it.

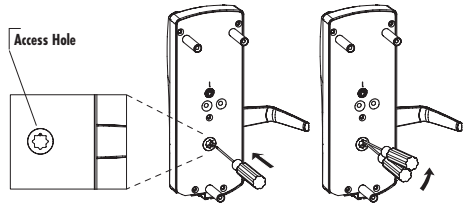

B. The lever is field reversible. If the handing is incorrect, insert a small pick or flat screwdriver in the hole in the hub as shown. Gently pry back the spring clip inside the hub, and remove the handle.

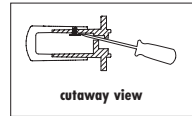

cutaway view

3. Install the Batteries (Not for PowerPlex 2000 versions)

Three AA batteries should already be installed in the battery holder (J). Insert the battery holder into the outside housing and secure it using the 6-32 X 3/8" spanner drive screw (K).

Note: If the lock makes a continuous buzzing noise or the red LED lights continuously, reset the electronics by removing the battery holder for ten seconds, then re-insert it.

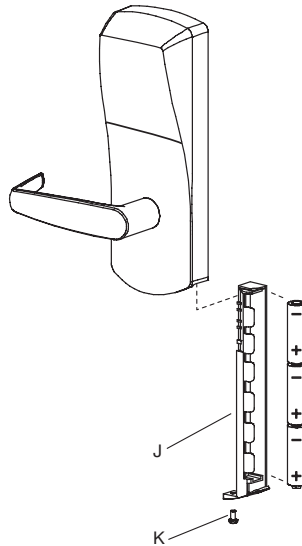

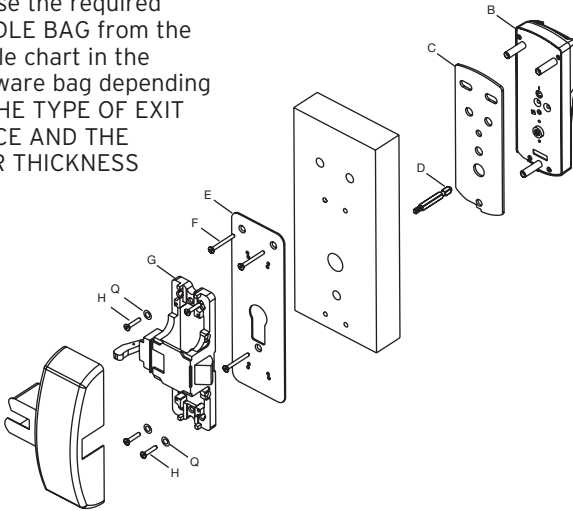

4. Install Lock & Exit Device on the door

- a. Choose the required SPINDLE BAG from the spindle chart in the Hardware bag depending ON THE TYPE OF EXIT DEVICE AND THE DOOR THICKNESS



- b. Insert the slotted end of the spindle (D) into the outside housing until it locks, at the correct position for the exit device (see Fig.4). The spindle can be removed by pulling on it, and re-inserted if oriented incorrectly.
- c. Place the outside housing (B) on the door. (with gasket (C) if required)
- d. Attach Adaptor Plate (E) to the lock (B) using Flat Head screws (F)(12-24nc).
- e. Attach the Exit Device chassis (G) to the Adaptor Plate (E) using 2 screws or 4 screws (H) depending on the Exit Device. For Detex only, use 2 or 4 Flat washers (Q).
- f. Make sure the lock and the Exit Device are well aligned and then tighten screws.
- g. Follow the manufacturer's instructions to complete the installation of the exit device and the appropriate strike.

Fig. 4 Spindle Position	
	
<p>Von Duprin 98/99 Von Duprin 9847/9947 Von Duprin 9827/9927 Precision 21/FL21 Precision 22/FL22 **Detex 10/F10 **Detex 20/F20 Yale 7100-36 Yale 7160 Yale 7170 Dorma F9300</p>	<p>Von Duprin 9875/9975</p>

** Detex 10/20 Series are Panic Hardware only. (Not fire rated)
 Detex F10/F20 Series are Fire rated hardware

D. INSTALLING OUTSIDE LEVER ON NON-MECHANICAL OVERRIDE

Assemble the lever on the outside housing in the horizontal rest position appropriate to the handing of the door. Simply push the lever onto the tube until it clicks in place. If more force is required, use a rubber mallet. Test the attachment of the handle by pulling on it to make sure it is securely fastened.

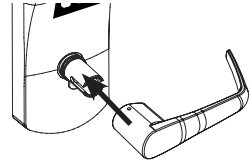

E. REVERSING THE OUTSIDE LEVER FOR SERIES WITHOUT MECHANICAL OVERRIDE

The lever is field reversible. If the handing is incorrect, insert a small pick or flat screwdriver in the hole in the hub as shown. Gently pry back the spring clip inside the hub, and remove the handle.

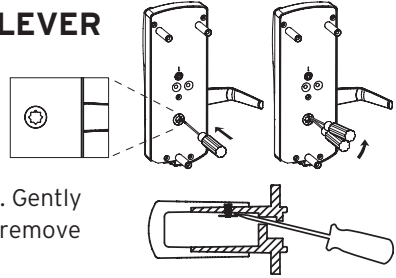

F. K-I-L CYLINDER ADAPTOR ASSEMBLY INSTRUCTIONS

F-1 Adaptor A

Fits: Schlage Primus 20-724-XXX
 Schlage Everest 21-020-XXX
 ASSA V-10 Schlage key way
 Ilco 1599SC-XXX



- Remove key from cylinder
- Remove threaded nut (#9) by pressing down pin (#5)
- Remove tailpiece (#7) and any other plate or washer (#6 & #8), if applicable
- Be careful not to loose the pin and spring
- Replace with AdaptorA (# 10) with small diameter facing upward
- Replace the threaded nut (#9) by pressing down pin (#5)
- Pin must be locked in a groove, if not unscrew until it reaches the closest groove test with key that cylinder rotates freely
- If not, press pin and unscrew one groove at a time and re-test
- The cylinder is now ready to be used
- Go to Section G

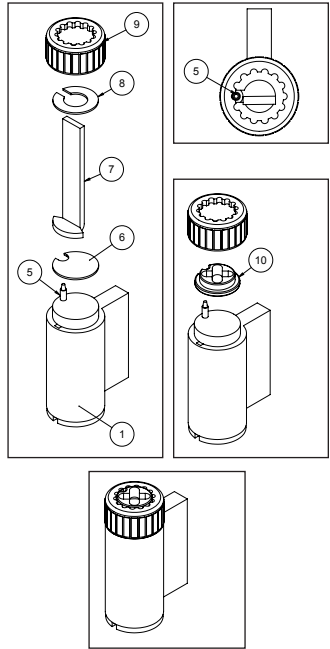

F-2 Adaptor B

Fits: Medeco M3-Bi-Level 20J200V1-XXX
 Medeco Biaxial 20W200V1-XXX
 Medeco 3-BX-3 20T200V1-XXX
 Medeco M3-Bilevel 8 20J200H1-XXX
 Medeco Keymark X4 20N200V1-XXX



- Remove key from cylinder
- Remove screws (#2)
- Remove old adaptor (#3)
- Replace with Adaptor B (#4)
- Replace screws (#2)
- Test with key that cylinder rotates freely
- The cylinder is now ready to be used
- Go to Section G

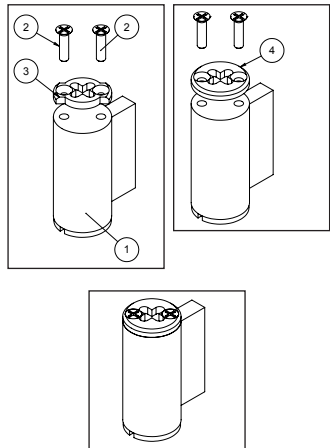

G. INSTALLING OPTIONAL K-I-L KEY OR BEST REMOVABLE CORE OVERRIDE AND OUTSIDE LEVER

G-1 Upon unpacking, the lock housing with mechanical override should look like the diagram below with:

- The small indents (i) on the cross of the override shaft (m) in line horizontally
- The plastic washer (c) on the drive tube
- The lever catch (f) in the out position
- Cylinder (j) and 2 keys (n) (included in the hardware bag)
- Shaft override tool (o) (included in the hardware bag)

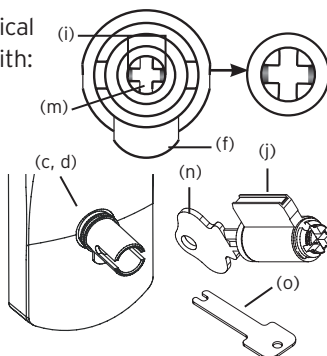

G-2 Using the override shaft tool (o), turn the override shaft clockwise until it stops so that the two small indents on the cross are now vertically in line.

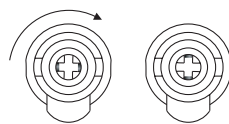

G-3 Push in the lever catch (f) firmly.

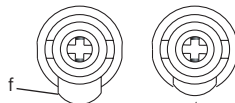

G-4 Insert the cylinder (j) into the lever handle (h).

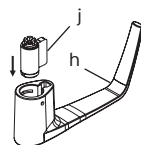

Note: For Best Removable Core, use Steps G-5, G-6 and G-7, then proceed to G-10 and continue. For Optional K-I-L Key, skip ahead to G-8 and proceed as normal.

For Best Removable Core

G-5 Insert 6-pin Best adapter (thicker) into 6-pin interchangeable core or insert 7-pin Best adapter (thinner) into 7-pin interchangeable core. Insert the adapter until it makes contact with the removable core.



G-6 Using the control key, assemble the removable core with its adapter into the lever. Remove control key.

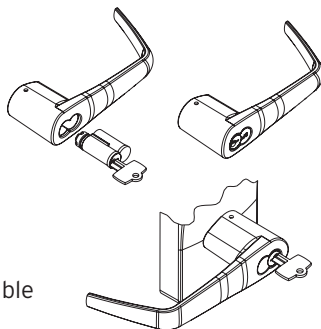

G-7 Insert the change key into the removable core.

For Optional K-I-L Key

G-8 Put the cylinder plug (k) into the lever (h).

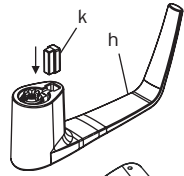

G-9 Making sure that the cylinder plug (k) does not fall out, insert the key into the cylinder (j). The key will be horizontal.

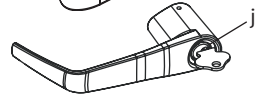

Caution: The position of the key is very important. If the lever is not assembled with the key in the correct position before placing the lever on the housing, the inside mechanism of the lock could be damaged if the lever is rotated and forced.

G-10 For Right-Handed Levers: Turn the key clockwise until it stops so that it is in the vertical position and the countersink (g) is in the top position.

Countersink (g) in the top position

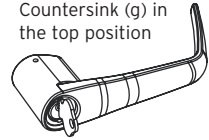

For Left-Handed Levers: Turn the key clockwise until it stops so that it is in the vertical position and the countersink (g) is in the bottom position.

Countersink (g) in the bottom position

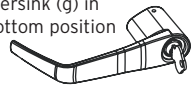

G-11 Fit the lever handle (h) onto the drive tube. It should rest approximately $\frac{1}{16}$ " (2 mm) from the body of the housing. If it can't be pushed that close to the housing, the lever catch (f) is probably not pushed in. Push it in. If the lever catch (f) is stuck, the override shaft is in the wrong position. The two small indents on the cross of the override shaft must be vertically aligned.

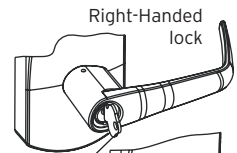

Countersink (g) in TOP Position



Countersink (g) in BOTTOM Position

G-12 Press the lever firmly against the housing while turning the key counter-clockwise (this applies to both Right-Handed and Left-Handed locks) until it is in the horizontal position.

Important: If it is not possible to turn the key counter-clockwise to complete this step, the spring washer (d) may be too tense: Tap the lever carefully with a rubber mallet to loosen the spring washer (d). Cover the lever handle with a cloth or other material to protect the finish of the metal.

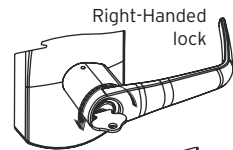

Left-Handed lock

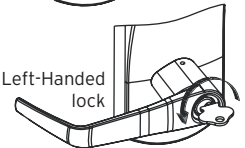

G-13 Remove the key. The lock will look as shown at right.

G-14 Gently check the rotation of the lever handle. It should easily rotate approximately 45°.

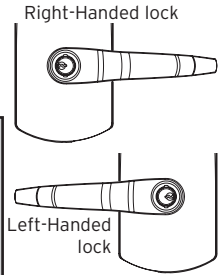

Troubleshooting: If you have assembled the lever and housing with the key in the wrong position, the key will get stuck. To remove the key, turn it so that it is in the vertical position and insert a small flat screwdriver into the hole under the lever handle to push the lever catch in (f). Remove key. If it is still stuck, turn the key clockwise until it stops to the horizontal position and push the Lever Catch in again with the small screwdriver. Remove key.

Troubleshooting: Right-Handed Lock: Turn the lever handle clockwise without forcing it. If it stops at approximately 15°, it was not assembled correctly. Do not try to force it to turn - this will damage the inside mechanism of the lock. Release the lever handle. Insert the small screwdriver into the small hole on the underside of the lever handle and push in the lever catch.

Re-do steps in section D

Left-Handed Lock: Turn the lever handle counter-clockwise without forcing. The drive hub should not rotate when the lever handle is turned. If it does, it was not assembled correctly. Release the lever handle. Insert the small screwdriver into the small hole on the underside of the lever handle and push in the lever catch.

Re-do steps in section D

G-15 Using the 5/64" Allen Key, tighten the set screw while pushing the lever against the plastic washer to remove the lever play.

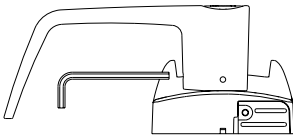

H. TESTING THE OPERATION OF THE OUTSIDE LEVER

H-1 Verify that the lever has been correctly attached to the housing:

- a. Remove key.
- b. Insert a small flat screwdriver into the hole on the underside of the lever handle and push in the lever catch.
- c. Pull on the lever.

You should not be able to remove the lever. If the lever comes off of the housing, the lock is not assembled correctly. Return to steps in section D and repeat this verification process.

H-2 Test the Movement of the Lever

(without the key in cylinder)

- Turn the lever (h) clockwise for a Right-Handed lock or counter-clockwise for a Left-Handed lock
- Release the lever slowly. It should return freely to its horizontal position.

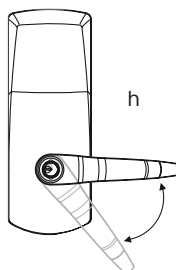

I. TESTING THE MECHANICAL KEY OVERRIDE WITH CHANGE KEY

Important: The Key Override itself does not retract the latch or deadbolt. Do not use too much force when turning the key as this may damage the unit. To retract the latch, turn the key clockwise until it stops, release the key and turn the lever.

Note: The lever must stay in the horizontal position when turning the key (do not try to turn the key while turning the lever) or the override mechanism will not work.

- I-1 Without using the key, turn the lever clockwise for Right-Handed locks or counter-clockwise for Left-Handed locks. The inside drive hub should not rotate when the lever turns.

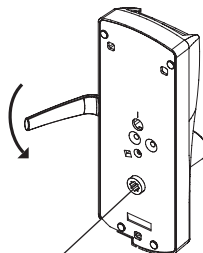

Inside drive hub does not move

- I-2 With the lever (h) in the horizontal position, insert the key (n) into the cylinder and turn it clockwise until it stops. (This applies to both Right and Left-Handed locks.)

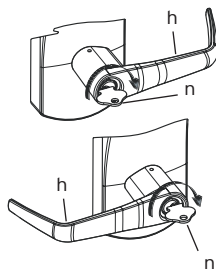

- I-3 Let go of the key, and again turn the lever handle (h) clockwise for Right-Handed locks or counter-clockwise for Left-Handed locks. Now the inside drive hub (b) should rotate in the same direction as the lever handle when it is turned.

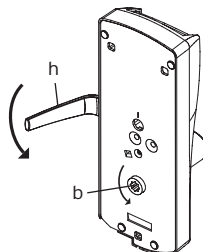

I-4 Install cap (i) to cover key hole. The cap has a small groove on one edge (to allow ease of removal). This should be facing down. Insert bottom snap of cap in lever hole below the cylinder. With a small screwdriver, push top snap of cap down while pushing the cap into place.

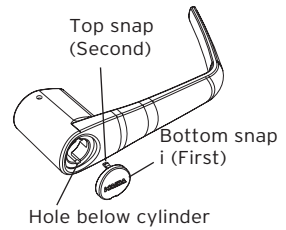

I-5 To remove the cap (i), insert a small flat screwdriver into this groove and gently pry the cap off, being careful not to damage it. Cover the bottom of the lever to protect the finish from being scratched through the process of removing the cap.

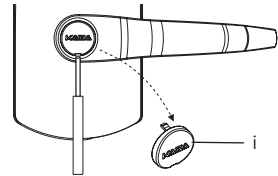

J. CHANGING KEY-IN-LEVER LOCK CYLINDERS

J-1 Loosen the set screw to free the lever (just 1/4 to 1/2 turn).

J-2 Remove the cap from the outside lever (h).

J-3 Insert key (n).

J-4 Turn the key clockwise until it stops.

J-5 Release key (n).

J-6 Use a small flat screwdriver to push in the lever catch through the small hole underneath the outside lever

J-7 Pull the outside lever (h) off of the lock housing. Be careful not to lose the cylinder plug (k). If it is difficult to pull the lever, slightly tighten or loosen the set screw

J-8 Replace the old cylinder with the new one in the lever handle. Only the same kind of cylinder with 2 grooves in cross in the end of the cylinder plug can be used on the lock.

J-9 Re-insert the cylinder plug (k).

J-10 While holding the cylinder (j) and plug (k) in place, insert the key.

J-11 Follow steps G-10 to G-14 and Test as per steps H and I.

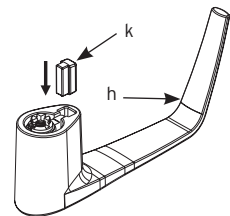
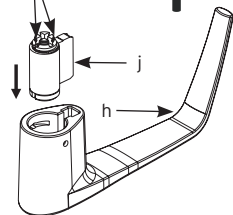
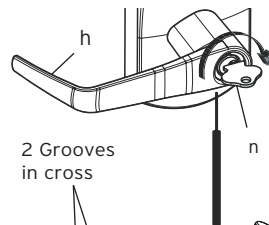
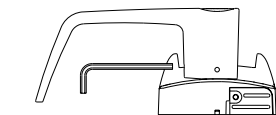

K. CHANGING BEST-TYPE CORE

K-1 Use the control key to remove the removable core from the lever

K-2 Remove the adapter from the removable core and reassemble it on the new removable core.

Note: It is important that the new removable core has the same number of pins (6 or 7) as the dismantled one. If not, change the adapter to fit the core.

K-3 Check to make sure that the override shaft did not move and that the 2 small indents on override shaft are still vertical (see below). Then, using the control key on the new core, assemble the new removable core on the lever.

K-4 Test the locks using Steps H and I.

L. REMOVING AND REASSEMBLING THE OUTSIDE LEVER

L-1 Loosen the set screw to free the lever (just 1/4 to 1/2 turn).

L-2 Insert the change key in the cylinder.

L-3 Turn the key clockwise until it stops (for both right and left-hand locks).

L-4 Release the key.

L-5 Use a small flat screw driver to push in the lever catch through the small hole underneath the outside lever.

L-6 Pull the outside lever off of the lock housing. Be careful not to lose the adapter.

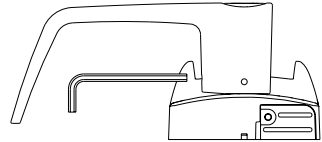

Important: Assemble the lever, cylinder and lock components before affixing the entire unit to the door.

L-7 Ensure that the two small indents on the cross are now vertically in line. (The cylinder or override shaft tool can be used to turn override shaft.)

L-8 Push in the lever catch (f) firmly.

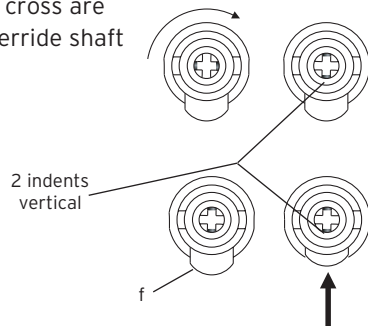

M. INSTALLING RUBBER BUMPERS

M-1 Close the door and apply pressure making sure the deadlatch (a) rests on the strike plate (b) as shown. Standing on the frame (door stop) side of the door, check for gaps between the door and the frame on the three sides of the frame (left, right, and top).

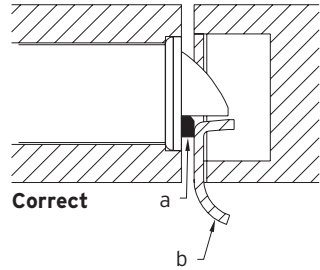

M-2 Mark locations where the gaps are approximately $\frac{3}{16}$ " (5 mm). Make sure these locations are free from grease and dust. Peel the bumpers (c) from their protective backing without touching the adhesive surface and stick them on the marked locations.

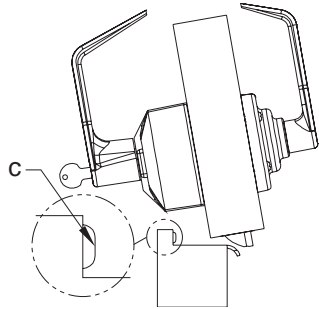

Note: Allow 24 hours for adhesive to set before testing. The door may be operated normally during this time.

N. INSTALLING BATTERY PACK (Not for PowerPlex 2000 Versions)

Note: If the lock makes a continuous buzzing noise or the red LED lights continuously, reset the electronics by removing the battery holder for ten seconds, then reinsert it.

N-1 Three AA batteries should already be installed in the battery holder (q).

N-2 Insert the battery holder into the outside housing and secure it using the 6-32 x $\frac{5}{16}$ " (8 mm) screw (r).

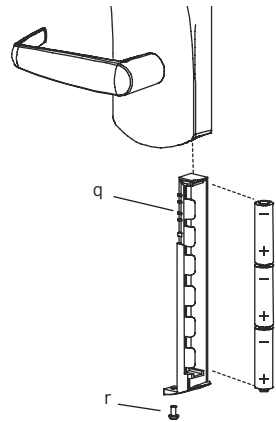

O. TESTING THE OPERATION OF THE LOCK

- O-1** Rotate inside lever and hold. Ensure that the latch is fully retracted and flush with the latch faceplate. Release the inside lever; the latch should be fully extended.
- O-2** For PowerPlex 2000 you need to activate the outside lever 3 to 4 times to power the lock prior
- O-3** Enter the factory-set combination: 1,2,3,4,5,6,7,8. You should see a green light and hear a high pitched tone as you push each button. When the lock opens, you will briefly hear the sound of an electronic motor. Rotate outside lever and hold. Ensure that the latch is fully retracted and flush with the latch faceplate. Release the outside lever; the latch should be fully extended. When the lock re-locks, you will again hear the motor.
- O-4** With the door open, verify functionality of the mechanical Key Override as detailed in Section F.



Door
Hardware



Electronic
Access & Data



Mechanical
Key Systems



Lodging
Systems



Entrance
Systems



Interior Glass
Systems



Safe
Locks



Service

